

Modeling and Analysis of Multilayer, High Voltage Power Modules Design Using Generalized Multiport Network

As 10 kV high voltage modules become more commercialized, the issue of the high electric field becomes urgent. There are many novel ways to reduce the electric field where the multilayer stacked substrate configuration is a promising solution. The internal cross section of a multilayer half-bridge, high voltage power module with stacked substrates is shown in Fig. 1.

However, the voltage of the middle metal layer is easily affected by the layout and operating condition of the top metal layers, especially for half-bridge modules.

This work proposes an electric circuit of multilayer stacked substrates half-bridge modules with a multiport network, which is shown in Fig. 2 (a). It is a generalized multiport electric network with individual parallel RC parameters and voltage excitation to reflect arbitrary layout patterns and voltage waveforms.

The voltage waveform of the input top layer voltage and calculated middle layer voltage when the half-bridge module is running in the three-level flying capacitor inverter are displayed in Fig. 2 (b). It is shown that the corresponding analytical time-dependent model of the middle layer voltage can be derived to provide programmable and expressible boundary conditions for the following electric field simulation and analysis.

Finally, this work fabricates stacked substrate prototypes with different layouts and materials to validate the effectiveness and accuracy of the modeling. The experimental results demonstrate that the proposed analytical model can calculate the middle layer voltage with a maximum error of >3.0% under sinusoidal, square voltage waveforms and different module topologies.

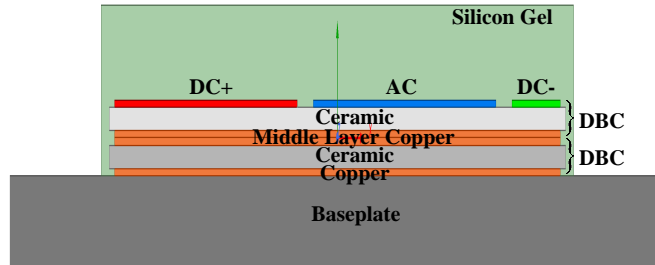

Fig. 1. Internal cross section of multilayer half-bridge high voltage power module with stacked substrates

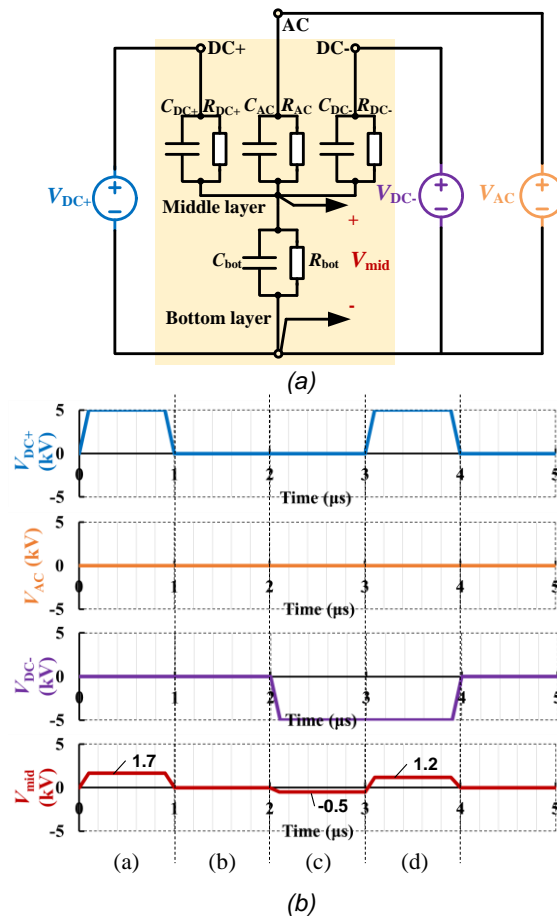

Fig. 2. (a) Electric circuit of multilayer stacked substrates half-bridge module with multiport network (b) Waveform of input top layer voltage and calculated middle layer voltage